

CAD FILE:

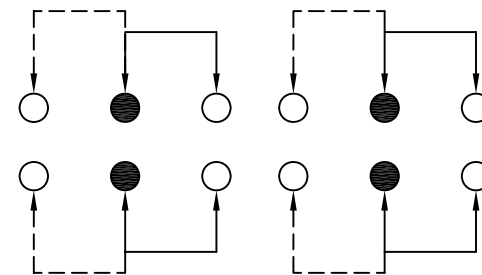

SCHEMATIC (NON-SHORTING)

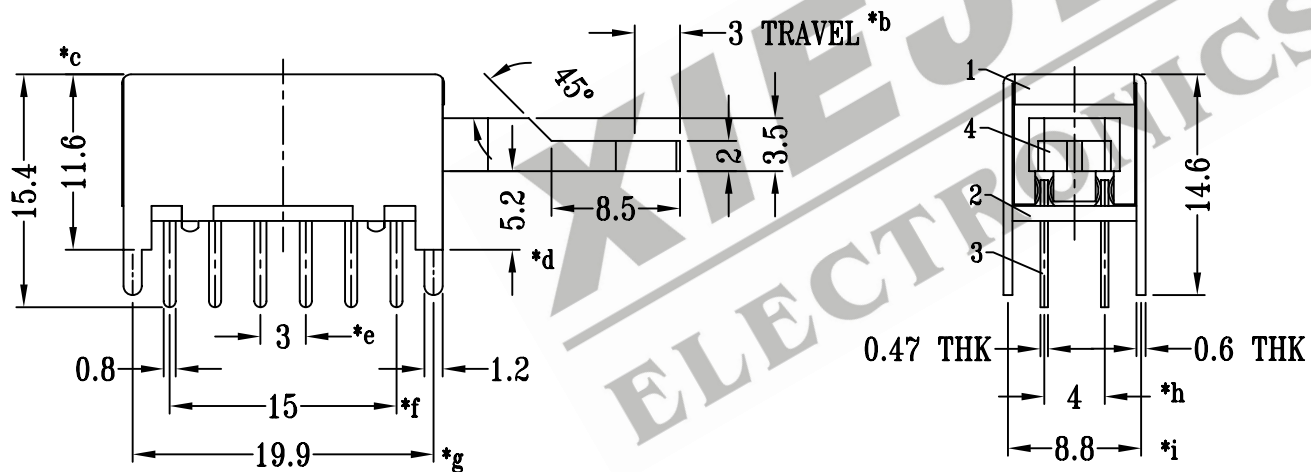
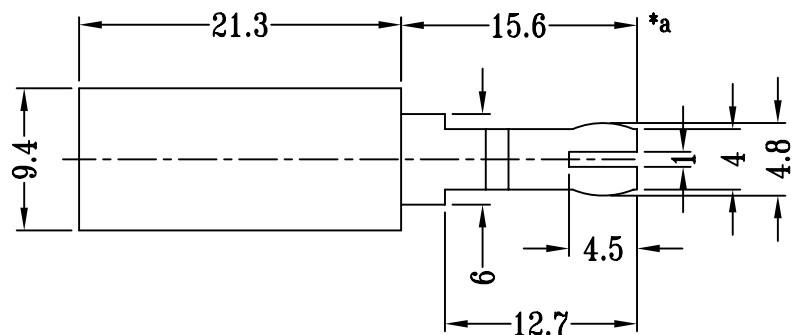
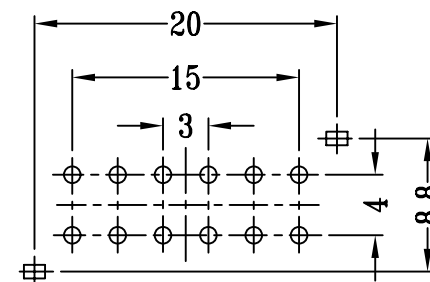

P.C.B LAYOUT

注:带“*”表示关键尺寸(9个)

NO.	PARTS	MATERIALS	Q'TY	FINISH	TOLERANCE UNLESS SPECIFIED	SHENZHEN XIEJIA ELECTRONICS CO.,LTD.				
8										
7										
6	SPRING	STEEL WIRE	1	TEMPER	WITHIN: 1.5±0.1mm OVER: 1.5±0.2mm	ISSUE	DATE	DESCRIPTIONS OF REVISION		APPD.
5	CONTACT CLIP	PBS STRIP	4	Ag PLATED						
4	KNOB	ABS	1	BLACK				UNIT: mm		DRWG NO.: XJ-DR-PS42F31-00
3	TERMINAL	BRASS STRIP	12	Ag PLATED OVER Ni PLATED				SCALE: 2:1		DWN. ZHOUYU 2005-12-9
2	BASE	PHENOLIC RESIN	1	NATURAL				MODEL: PS-42F31		CHK'D FANGYING 2005-12-9
1	FRAME	STEEL STRIP	1	Ni PLATED				ALL MATERIALS MUST BE COMPLIANT TO ROHS		APPD. KANGXINAN 2005-12-9